

Innovation First, Inc.

2005 Full-Size Robot Controller Reference Guide

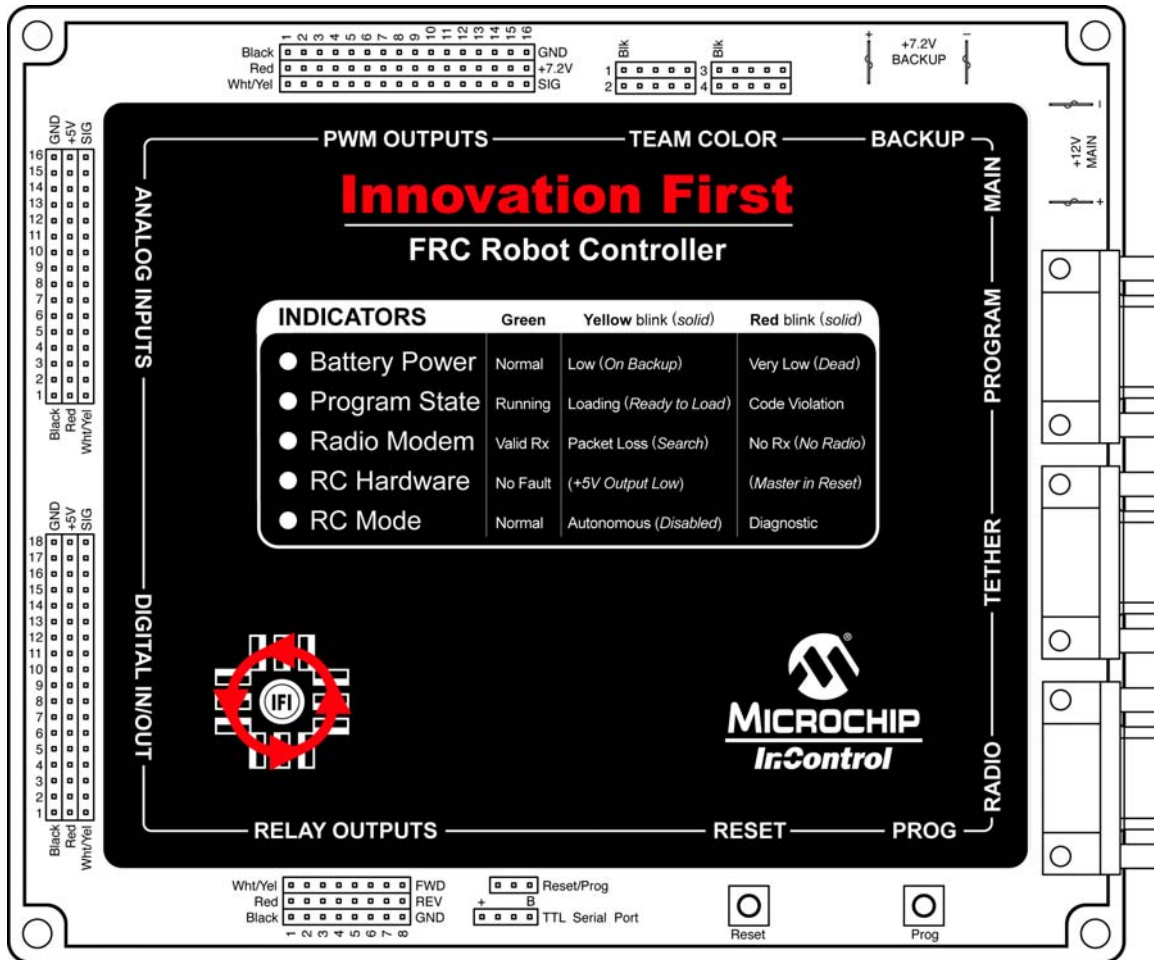
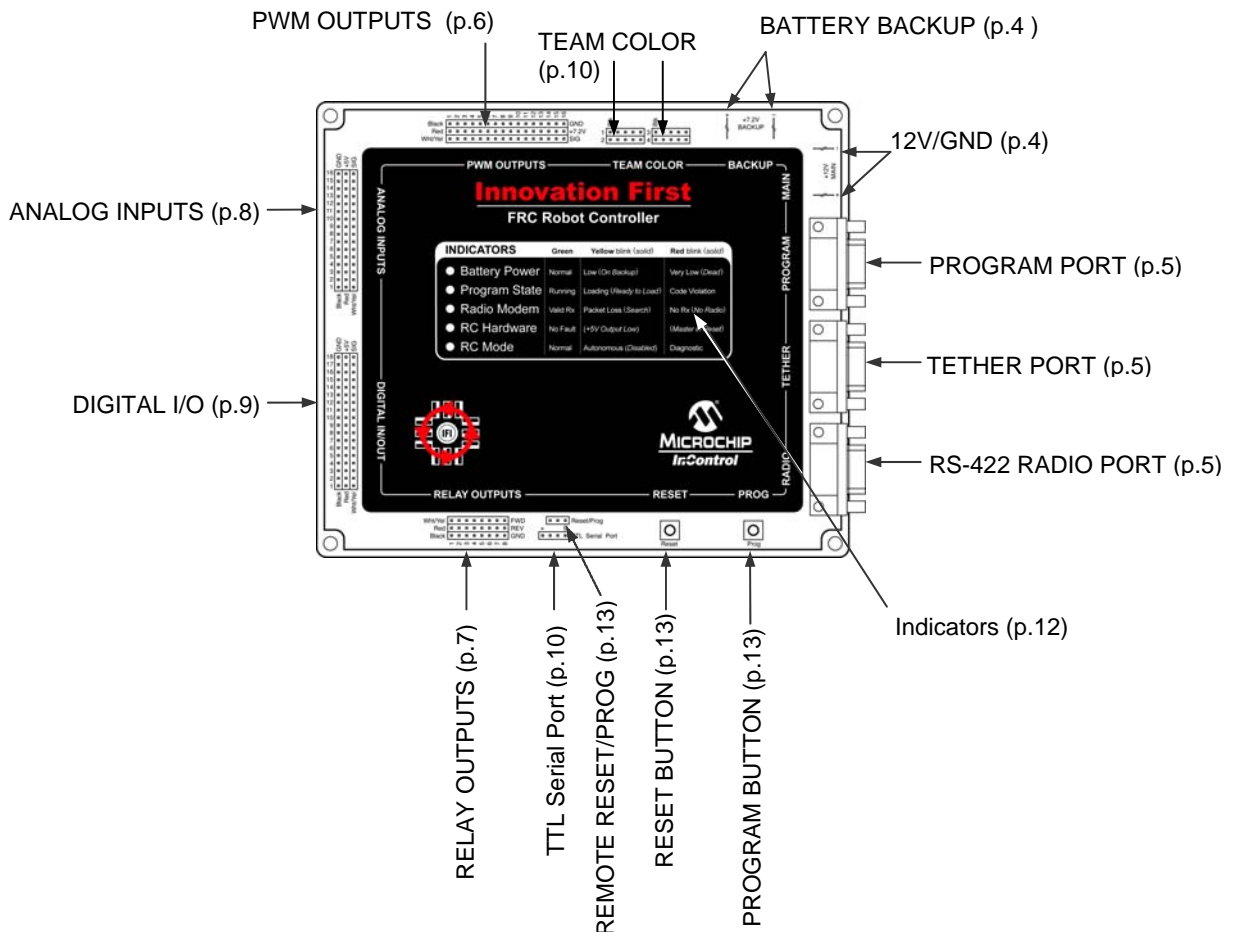

Table of Contents

- 1. Robot Controller Overview..... 3
- 2. Main Power Input 4
- 3. Battery Backup Power 4
- 4. PROGRAM..... 5
- 5. TETHER 5
- 6. RADIO 5
- 7. PWM Outputs 6
- 8. Relay Outputs..... 7
- 9. Analog Inputs..... 8
- 10. Digital Inputs/Outputs..... 9
- 11. Team Color Light Connectors 10
- 12. Setting the Team Number 10
- 13. Autonomous Mode..... 10
- 14. TTL Serial Port 11
- 15. Robot Controller Indicators 12
- 16. PROG Button 13
- 17. RESET Button 13
- 18. RESET/PROG Connectors 13
- 19. Circuit Breakers 13
- 20. Programming the Robot Controller 14
- Appendix A: Document Version History..... 15



1. Robot Controller Overview

The Robot Controller (RC) receives information from the Operator Interface, gathers additional information from sensors on-board the robot, determines how the robot should function, and instructs the robot to perform the functions. The Robot Controller also sends data back to the Operator Interface, giving the human operator(s) feedback of critical information.

There are 2 types on Robot Controllers, the Full-Size Robot Controller and the EDU Mini Robot Controller. The Full-Size Robot Controller is a large unit with an external Radio Modem. The EDU Mini Robot Controller has fewer inputs and outputs and uses a standard hobby R/C transmitter/receiver pair for remote operation. This document is concerned only with the Full-Size Robot Controller.

The Full-Size Robot Controllers gather on-board sensor data via the ANALOG and DIGITAL inputs. There are 16 analog inputs and 18 digital input/output pins on the Full-Size Robot Controller. Switches of various types may be connected to the digital inputs, and external circuitry can be triggered using the digital outputs. Sensors that provide a 0-5V output, such as potentiometers and gyros (yaw rate sensors) may be connected to the analog inputs.

The Robot Controller takes the collected data from both the Operator Interface and the on-board sensors and then processes it using its internal microcontrollers. There are two Microchip PIC18F8520 microcontrollers inside the Robot Controller. The first is the Master processor which handles radio and tether communications, generates most of the PWM output signals, and oversees the general operations of the Robot Controller. The second PICmicro[®] is the User processor, and is programmable by the user. The user's program takes the input data, determines what to do with the outputs to make the robot behave as desired, and sets the PWM and Relay outputs to the appropriate states. The Robot Controller comes with a default program that will handle most robot control needs. If more sophisticated control of the robot is desired, then the default program can quickly be modified to provide the required functions of the robot.

The Full-Size Robot Controller has 16 PWM outputs and 8 RELAY outputs. The PWM outputs are used to drive Victor 883 speed controllers and servos. The most common use of these outputs is to control a variable speed motor. The PWM outputs will also control most industry standard servos. The Relay outputs are used to drive Spike bi-directional relay modules. The most common use of these outputs, when connected to a Spike, is to drive small motors in Full Forward, Full Reverse or Off. The Relay outputs, in conjunction with a Spike, can also be use to turn On or Off solenoids, pumps, etc.

The Robot Controller has an Autonomous Mode, in which the Operator Interface is not needed. The RC will run as programmed in Autonomous Mode, except there is no remote user input, only input from onboard sensors.

Reference Documents (available at www.InnovationFirst.com)

- Size, weight, and mounting info
- Frequently Asked Questions (FAQs)
- FIRST Control System Quick Start Guide
- 2005 FRC Default Code project file
- Programming Reference Guide

2. Main Power Input

The +12V and GND connectors on the Robot Controller are intended to accept power from a +12V battery. The current draw for the Robot Controller is typically between 0.75A to 1.5A. The maximum voltage allowable is +15.0V. Exceeding the +15.0V limit may damage internal voltage regulators and will void the warranty. The minimum required voltage to maintain radio link is +7.0V.

Use female 0.25" quick disconnect lugs to connect the +12V and GND wires to the Robot Controller. Use a minimum of 16GA wire to minimize voltage drop to the Robot Controller. Fuses prior to the Robot Controller are not required. Always follow FIRST Competition rules when building for FIRST competitions.

When wiring to the Robot Controller, ensure that the +12V and GND lugs do not short at the Robot Controller. Connect GND to the corner connector and +12V to the inside connector. The Robot Controller is internally protected from reverse polarity.

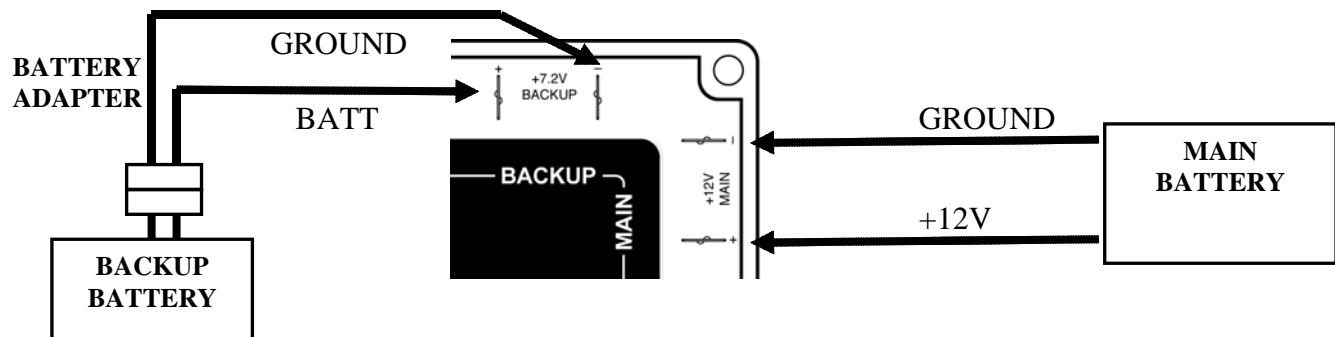

3. Battery Backup Power

Connecting a 7.2V battery to this receptacle will ensure that if the power supply coming in from the Main Power Input drops out or temporarily dips, the Robot Controller will not lose power and reset, causing the program currently running to restart. This can occur if the Robot Controller and the rest of the robot share the same power supply, and a high current draw (from stalled motors, for example) causes that power supply voltage to droop. In this situation the small battery connected to the Battery Backup receptacle will keep the Robot Controller running without resetting when the main power comes back up. The Battery Backup circuit also supplies power to the center pins of the PWM OUTPUTS, which is required to operate servos.

The Robot Controller cannot start running from Battery Backup power only. It requires Main power connected at the required voltage to initially power on. If Main is lost and a link with an OI had been established, the RC will continue to operate with only Battery Backup power for approximately 3.5 minutes before it automatically turns itself off. If Main is lost but a link was never established with an OI, the RC will continue to run until the Battery Backup power is exhausted, or until the RESET button is pressed.

The Battery Backup connector is intended to accept power from a 7.2V battery. A 7.2V Battery and battery to 0.25" quick disconnect adapter is available from www.InnovationFirst.com.

4. PROGRAM

The PROGRAM port is used to change the program on the Robot Controller. This port is intended to connect to a PC's serial port. Use a DB9 Male-Female Pin-to-Pin cable (maximum length 6 ft.) to connect the PROGRAM port on the Robot Controller to a PC serial port. For more details on downloading a new program to the RC, see Section 20 of this document.

5. TETHER

The TETHER port is intended to connect the Robot Controller directly to the Operator Interface. Tether is used to communicate to an Operator Interface over a "hard" wire connection instead of using a wireless radio link. The TETHER port passes the same data as the radios, allowing full functionality without the use of radios. A tether connection can be made with or without Radio Modems connected. The system will always use tether if it is available. When a tether connection is made, you will see the status indicators on the Radio Modems switch to Standby. Both the Operator Interface and the Robot Controller will automatically detect a tether connection and switch to tether without requiring power OFF or a reset.

A tether connection also provides power to the Operator Interface from the Robot Controller's +12V battery. Tether power provides a means to power the Operator Interface when 115V 60Hz AC power is not available. Tether power is useful before or after competition rounds to check your system or collapse your robot.

Tethering is also required to set the team number of your RC, as detailed in Section 12 of this document.

Use a DB9 Female-Female Pin-to-Pin cable (maximum length 6 ft.) to connect the Robot Controller to the Operator Interface. This is different from the standard Male-Female cable used for the Radio port or the Program port.

Caution: This port is not intended to interface with a computer.

6. RADIO

The port labeled RADIO is intended to connect to the Innovation First RS-422 Robot Controller Radio modem only. This port uses RS-422, instead of RS-232, to minimize noise interference in the communication link. Caution: Do not connect any other equipment to this port.

There are two different radios provided with the system. Be sure to connect the Robot Controller to the radio that is marked "Robot Controller" by the black antenna. Use a DB9 Male-Female Pin-to-Pin cable (maximum length 6 ft.) to connect the Robot Controller to the RS-422 Radio modem.

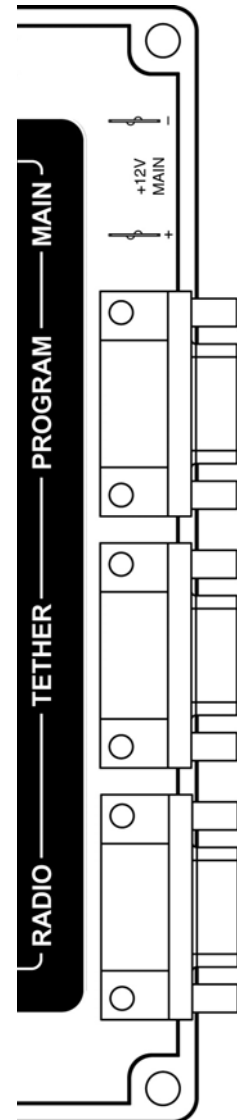

7. PWM Outputs

The PWM outputs are used to drive Victor 88x series speed controllers and servos on the Full-Size Robot Controller. The most common use of these outputs is to control a variable speed motor from a joystick axis connected to the Operator Interface. The PWM outputs will also control most industry standard servos if a 7.2V backup battery is connected to the Battery Backup connector to power them. Make sure that your servos can handle a fully charged 7.2V battery (8.4 volts) before doing this, however. Each of the PWM outputs generates a unique Pulse Width Modulated (PWM) signal corresponding to a specific output of the User processor's program. Custom User code can be written to control the PWM outputs as desired.

Use a PWM/Relay extension cable to connect an appropriate device to one of the PWM output ports. Be sure to connect the cable so the black wire is on the indicated side. A Y-cable can be used on any PWM output to drive two like devices at the same time.

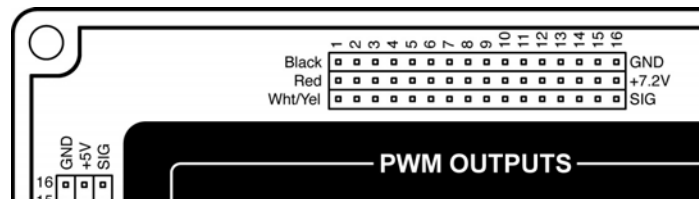

Warning: The PWM outputs are only to be used with Victor/Thor 88x series Speed Controllers or servos. The use of other speed controllers may damage the unit and will void the warranty.

Table 7.5a below shows which of the PWM outputs are controlled by joysticks on the Operator Interface. This table is only valid for Default code. These functions and variable names may be changed for custom user programs.

Table 7.5a: PWM Output Map (Default Code Only)

PWM Output	User Variable	Output Controlled by
PWM1	p1_y	Port 1 joystick Y-axis
PWM2	p2_y	Port 2 joystick Y-axis
PWM3	p3_y	Port 3 joystick Y-axis
PWM4	p4_y	Port 4 joystick Y-axis
PWM5	p1_x	Port 1 joystick X-axis
PWM6	p2_x	Port 2 joystick X-axis
PWM7	p3_x	Port 3 joystick X-axis
PWM8	p4_x	Port 4 joystick X-axis
PWM9	p1_wheel	Port 1 joystick Wheel
PWM10	p2_wheel	Port 2 joystick Wheel
PWM11	p3_wheel	Port 3 joystick Wheel
PWM12	p4_wheel	Port 4 joystick Wheel
PWM13	mixing function	Port 1 joystick Y & X –axes mixed
PWM14	mixing function	Port 1 joystick Y & X –axes mixed
PWM15	mixing function	Port 1 joystick Y & X –axes mixed
PWM16	mixing function	Port 1 joystick Y & X –axes mixed

Note: Twelve Robot Controller digital inputs are configured by the default code to act as limit switches for PWMs 3, 4, 9-12. Refer to Section 10 on page 9 for more details.

PWMs 13-16 are meant to be used if one desires to control the robot using only one joystick. The left and right drive motors are controlled by mixing the X and Y axes of joystick 1.

8. Relay Outputs

The Relay outputs of the Full-size Robot Controller are used to drive Spike bi-directional relay modules. The most common use of these outputs, when connected to a Spike, is to drive small motors in Full Forward, Full Reverse or Off. The Relay outputs, in conjunction with a Spike, can also be use to turn On or Off solenoids, pumps, and lights from a joystick button on the Operator Interface. Each of the eight ports generates two binary signals corresponding to a specific output of the User program. Custom User software can be used to control the Relay outputs as desired.

Refer to the Spike Users Manual (available at www.InnovationFirst.com) for detailed instructions on wiring to motors, solenoids, pumps, and lights. Use a PWM/Relay extension cable to connect a Spike to one of the Relay outputs. Be sure to connect the cable so that the black wire is on the indicated side. Each Relay output can be used with a Y-cable to drive two Spikes from the same output.

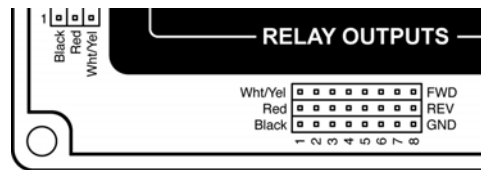

Table 7.6 below shows which of the Relay outputs are controlled by joysticks connected to the Operator Interface. This table is only valid for Default code. These functions and variable names may be changed in custom user programs. Refer to the Programming Reference Guide available at www.InnovationFirst.com for details on making such changes.

Table 7.6: Relay Output Map (Default Code Only)

Relay	Operator Interface		Operator Interface Control Switch	User code Variable
	Connector	Pin		
Relay 1 Forward	OI Port 1	2	Joystick Trigger Switch	p1_sw_trig
Relay 1 Reverse	OI Port 1	7	Joystick Thumb Switch	p1_sw_top
Relay 2 Forward	OI Port 2	2	Joystick Trigger Switch	p2_sw_trig
Relay 2 Reverse	OI Port 2	7	Joystick Thumb Switch	p2_sw_top
Relay 3 Forward	OI Port 3	2	Joystick Trigger Switch	p3_sw_trig
Relay 3 Reverse	OI Port 3	7	Joystick Thumb Switch	p3_sw_top
Relay 4 Forward	OI Port 4	2	Joystick Trigger Switch	p4_sw_trig
Relay 4 Reverse	OI Port 4	7	Joystick Thumb Switch	p4_sw_top
Relay 5 Forward	OI Port 1	10	Auxiliary OI Digital Input (unwired to joystick)	p1_sw_aux1
Relay 5 Reverse	OI Port 1	14	Auxiliary OI Digital Input (unwired to joystick)	p1_sw_aux2
Relay 6 Forward	OI Port 3	10	Auxiliary OI Digital Input (unwired to joystick)	P3_sw_aux1
Relay 6 Reverse	OI Port 3	14	Auxiliary OI Digital Input (unwired to joystick)	P3_sw_aux2
Relay 7 Forward	OI Port 4	10	Auxiliary OI Digital Input (unwired to joystick)	P4_sw_aux1
Relay 7 Reverse	OI Port 4	14	Auxiliary OI Digital Input (unwired to joystick)	P4_sw_aux2
Relay 8 Forward	-	-	(No OI input, turns on compressor via Spike relay if pressure switch is closed (low) across dig_in18 to ground)	!rc_dig_in18
Relay 8 Reverse	-	-	(No OI input)	"0"

Note: Four Robot Controller digital inputs are configured by the default code to act as limit switches for Relay 1 and Relay 2. Refer to Section 10 on page 9 for more details.

9. Analog Inputs

The analog inputs on the Robot Controller can be used to measure various conditions on the robot and trigger automatic responses by the control program. There are 16 analog inputs available on the ANALOG INPUTS connectors on the Full-Size Robot Controller.

Any sensor which outputs a variable 0-5V signal may be read with 10-bit resolution on these inputs. Popular devices include potentiometers and gyro (yaw rate) sensors. Potentiometers should be wired per the diagram below when connecting to the Analog Inputs. Always use 250 – 100KΩ potentiometers. For wiring yaw rate sensors, refer to the sensor manufacturer’s data sheet.

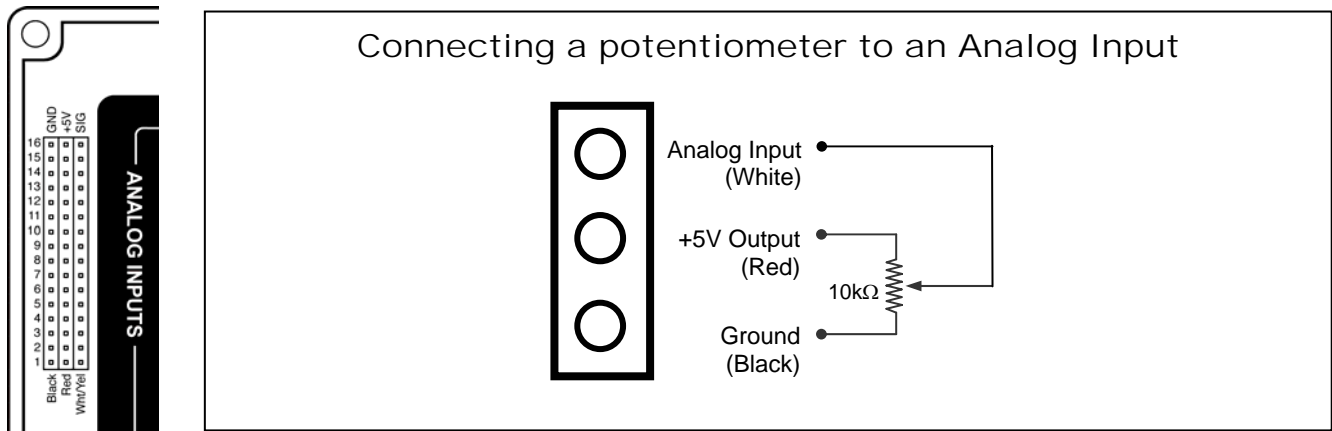

For details on reading and using values from the Analog Inputs, refer to the Innovation First Programming Reference Guide.

10. Digital Inputs/Outputs

The 18 Digital I/O pins on the Robot Controller can be configured individually as either inputs or outputs in the User program. For details on configuring them in software, refer to the Innovation First Programming Reference Guide.

When configured as inputs these pins accept signals of either 0 Volts or 5 Volts from sources such as switches or other external circuitry. A 0V signal will be read as a logic 0 in the software, and a 5V signal on the pin will be read as a logic 1. A 5V signal is not required because these pins are all pull-ups, which means that if left disconnected from any external signal, they will be pulled high to 5V. This means that all unconnected digital inputs will be read as a logic 1 in the software.

The most common use for digital inputs is for the connection of switches. Wire switches between the desired digital input signal pin and a ground pin. Digital inputs in the Default Code are “looking” only for ground signals to become “active”. Switches may be wired individually, in parallel, or in series.

For advanced users, the first six digital I/O pins can be configured as hardware interrupts. While powerful, this feature can cause undesired operation if improperly used. Therefore Innovation First will not provide support for this feature. More details on using interrupts can be found by referring to the 18F8520 microcontroller datasheet and the MPLAB® C18 C Compiler User’s Guide. The Default Code has an interrupt handler written for these pins, but you must still configure and enable the interrupts to use them.

Table 7.8: Digital Input/Output Pinout and Software Function

Pin	Function	C Variable Alias	C Default Code Function
1	Switch 1	rc_dig_in01	Relay 1 won't go Forward if rc_sw1 is ON
2	Switch 2	rc_dig_in02	Relay 1 won't go Reverse if rc_sw2 is ON
3	Switch 3	rc_dig_in03	Relay 2 won't go Forward if rc_sw3 is ON
4	Switch 4	rc_dig_in04	Relay 2 won't go Reverse if rc_sw4 is ON
5	Switch 5	rc_dig_in05	PWM 3 won't go Forward if rc_sw5 is ON
6	Switch 6	rc_dig_in06	PWM 3 won't go Reverse if rc_sw6 is ON
7	Switch 7	rc_dig_in07	PWM 4 won't go Forward if rc_sw7 is ON
8	Switch 8	rc_dig_in08	PWM 4 won't go Reverse if rc_sw8 is ON
9	Switch 9	rc_dig_in09	PWM 9 won't go Forward if rc_sw9 is ON
10	Switch 10	rc_dig_in10	PWM 9 won't go Reverse if rc_sw10 is ON
11	Switch 11	rc_dig_in11	PWM 10 won't go Forward if rc_sw11 is ON
12	Switch 12	rc_dig_in12	PWM 10 won't go Reverse if rc_sw12 is ON
13	Switch 13	rc_dig_in13	PWM 11 won't go Forward if rc_sw13 is ON
14	Switch 14	rc_dig_in14	PWM 11 won't go Reverse if rc_sw14 is ON
15	Switch 15	rc_dig_in15	PWM 12 won't go Forward if rc_sw15 is ON
16	Switch 16	rc_dig_in16	PWM 12 won't go Reverse if rc_sw16 is ON
17	Output	rc_dig_out17	Always a logic "0"
18	Input	rc_dig_in18	Drives Relay 8 Forward hi when rc_dig_in18 is low

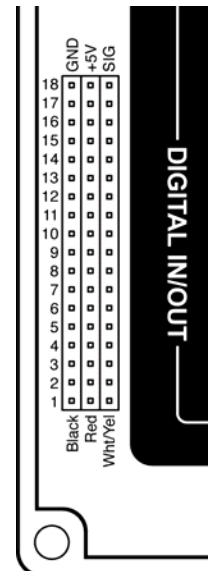

11. Team Color Light Connectors

There are four team color connectors which all output identical signals. Each connector is meant to drive one team color LED unit for identifying which team your robot is on. Team color LED units are included in your kit or are available from Innovation First.

By default, these LED units will display red if you are using the default practice channel of 40. If you use a channel adapter to change to another radio channel, the team color will differ. Channels 4, 22, and 40 will cause a red team color to flash, while channels 13 and 31 cause blue. In general, the user cannot control the team color, because it is set by the Arena Controller during competition.

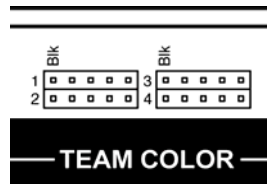

12. Setting the Team Number

Unlike previous Innovation First Robot Controllers, the current system does not have any dip-switches for setting the Team Number. In order to set the Robot Controller's Team Number, you must first set the Team Number on the Operator Interface, then connect the OI and RC using a tether cable. The Robot Controller will automatically read the Team Number from the OI and will store it internally in EEPROM. The Team Number will be remembered even if the Robot Controller's power is turned off. For instructions on setting the team number using the DIP switches on the OI, please refer to the Operator Interface Reference Guide.

13. Autonomous Mode

Autonomous Mode means that the RC will ignore all data from the Operator Interface and it will not require a link with the Operator Interface to execute code.

If you wish to run the Robot Controller exclusively in Autonomous Mode, one way to do this is to set your team number to zero. This is done by setting the team number on your OI to zero, linking your OI and RC by tether, and then disconnecting from tether. After your RC is reset it will be in Autonomous Mode.

To exit Autonomous mode if your team number is zero, you must re-tether and change the team number to anything but zero.

An additional method for getting into Autonomous Mode is described in the Operator Interface Reference Guide in the "Competition Control LED" section. See the Programming Reference Guide for details on how to program for Autonomous Mode.

14. TTL Serial Port

The four-pin header labeled “TTL Serial Port” is an auxiliary serial port from the User processor inside the Robot Controller. The PROGRAM connector is actually the User processor’s Serial Port 1, with circuitry to convert the TTL level signal to RS-232 levels so that it can be interfaced with a standard PC serial port. The TTL Serial Port connector is the User processor’s Serial Port 2, but without any conversion. This enables the Robot Controller to use serial communications with other TTL-level digital circuitry. If it is necessary to use this serial port to communicate with RS-232 devices (such as a PC), various TTL to RS-232 adapters can be purchased from the internet, or plans to make one’s own are also available from the internet.

Both Serial Port 1 and Serial Port 2 are available to the user through custom programs. While Innovation First does not support this feature, general programming information can be found in the Programming Reference Guide from the Innovation First web site, and more specifics on the Microchip PIC18F8520 microcontroller can be found in the datasheet from Microchip’s web site. Note that no dedicated handshaking lines are provided, but any of the digital I/O lines could be used for this purpose in software, if necessary.

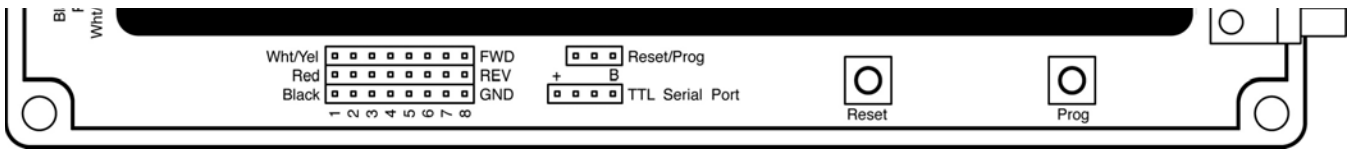

TTL Serial Port Pin-out

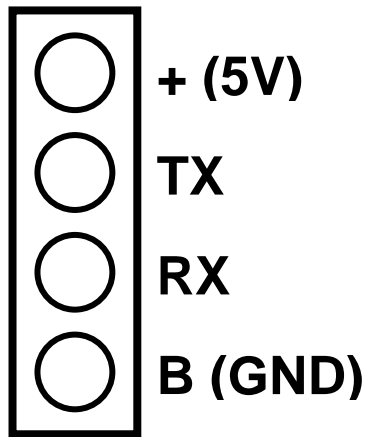

15. Robot Controller Indicators

The Robot Controller has the following LED indicators, as labeled on the RC cover.

Table 8.2: Robot Controller LEDs

Battery Power	Green blink	Input power from Main battery is ON from +12V/GND. Voltage reads between approximately 9.2V to 12V.
Battery Power	Yellow blink	Low main input voltage detected. Replace or recharge main battery soon, if used. Voltage reads between approximately 7.2V to 9.1V.
Battery Power	Yellow solid	Main battery voltage is below backup battery voltage. RC is now being powered by backup battery. Replace or recharge main battery soon, if used.
Battery Power	Red blink	Very low input voltage detected. If running from a battery, the RC is about to power down. Voltage reads between approximately 5.7V to 7.1V.
Battery Power	Red solid	Main and backup batteries are dead. RC is shut down. Voltage is below 5.7V.
Program State	Green blink	Normal operation. User processor is executing code.
Program State	Yellow blink	Downloading new program from the PC.
Program State	Yellow solid	Ready for bootload. Waiting for new program to be downloaded from the PC. PROG button was pressed on the Robot Controller.
Program State	Red blink	User processor is being held in reset due to a code violation or an infinite loop. Check code. Re-download the Default Code to help verify a coding problem.
Radio Modem	Green blink	Normal link between Robot Controller and Operator Interface.
Radio Modem	Yellow blink	Data is being missed between RC and OI. Possible causes include interference on the channel or the radios are out of range.
Radio Modem	Yellow solid	Searching for radio link to an OI with the same team number.
Radio Modem	Red blink	Link to OI has been lost, either by tether or radio.
Radio Modem	Red solid	Radio Modem not found. Check modem and cables.
RC Hardware	Green blink	Normal operation.
RC Hardware	Yellow solid	Internal 5V power for analog and digital I/O supply is in a high current condition. Check for shorts on pins.
RC Hardware	Red solid	Master in Reset.
RC Mode	Off	RC is disabled and waiting to link to an OI.
RC Mode	Green blink	RC is linked to an OI and is in Enabled mode. Operating normally.
RC Mode	Yellow blink	RC is in Autonomous mode because of commands from an OI or Arena Controller.
RC Mode	Yellow solid	RC is in Disabled mode because of commands from an OI or Arena Controller.
RC Mode	Red blink	RC in diagnostic mode.

16. PROG Button

The PROG button stops the User code from executing and puts the Robot Controller into a standby state in which it is waiting for new code to be downloaded from a PC. In this state the currently executing program will be stopped and the “PROGRAM STATE” LED will turn a solid yellow. See Section 20 for more information on downloading new code to the Robot Controller. IT IS NOW NECESSARY to press the PROG button on the RC to prepare it for downloading from the PC.

17. RESET Button

The RESET button performs a complete hardware reset of the Robot Controller, including the Master and User processors. Resetting also re-initializes the external radio to “Search” or channel scan mode. Power cycling the Robot Controller and pressing the RESET button both have the same result. The most common use for the RESET button is to restart the User processor in case of a programming error which has resulted in an infinite loop.

If the Robot Controller is running from Battery Backup power, you must press the RESET button to power off the RC after Main power is removed.

18. RESET/PROG Connectors

The three pins labeled “Reset/Prog” enable the user to remotely trigger a reset or download event. Connecting either the RESET (left) pin or the PROG (center) pin to the ground (right) pin would appear to the Robot Controller as if either the RESET or PROG buttons were pressed, respectively. This feature has been included so that wires can be run to remote buttons, switches, or circuitry for more convenient triggering if the buttons are inaccessible or buried in your robot. Remember that RESET is necessary to power down your RC when using Battery Backup.

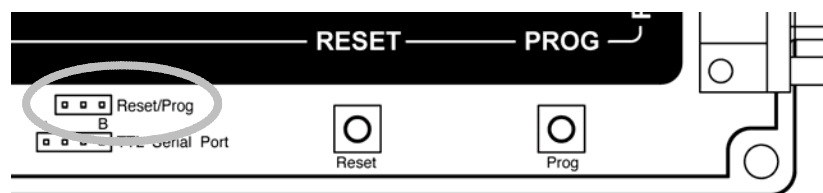

19. Circuit Breakers

The Robot Controller has two internal auto resetting circuit breakers. One protects Tether power and Team Color power from short circuits. This circuit breaker will trip when current exceeds 1.5 amps. The other circuit breaker protects the Battery Backup circuit. This circuit breaker will trip when current exceeds 4 amps. The center pin of the PWM OUTPUTS is connected to the Battery Backup circuit. This center pin is typically used to power servos.

20. Programming the Robot Controller

The Robot Controller is supplied with a Default program written using the C programming language in order to help get the robot up and running quickly. If more sophisticated control of the robot is desired, then a custom program can be quickly created by modifying the Default program. In order to facilitate the creation of a custom program, source code for the Default program is provided. The Default program project file is available at www.InnovationFirst.com. For complete details on creating custom programs for the Robot Controller, see the Programming Reference Guide.

The software necessary for writing a custom program are as follows:

MPLAB[®] IDE and C18 compiler from the C-Bot CD-ROM.

IFI Loader available from the C-Bot CD-ROM or www.InnovationFirst.com.

Once a custom program has been created and compiled according to the instructions in the Programming Reference Guide, the resulting .hex file must be downloaded to the Robot Controller. Brief instructions for doing this are below. For detailed steps, refer to the Programming Reference Guide.

1. Compile a valid program in *MPLAB[®] IDE*. You may also use the `FRC_Default.hex` file which has been pre-compiled to restore the default functionality.
2. Power ON the Robot Controller.
3. Connect a DB9 Male-to-Female Pin-to-Pin cable from the PROGRAM port to PC's serial port.
4. Run *IFI Loader* on the PC.
5. Click the "Browse" button and select the desired .hex file.
6. Push the PROG button on the RC until the PROGRAM STATE LED illuminates yellow, then release.
7. Click the "DOWNLOAD" button in *IFI Loader*.
8. Wait for download to complete. Before the new User program will start executing, a full-size FRC Robot Controller must have a Valid RX (link) to an OI or the RC must be in Autonomous Mode.

Successful Programming: PROGRAM STATE LED Green

After programming the Robot Controller, the Robot Controller must link to an Operator Interface using either tether or radio before the new code will begin executing. Once a proper link has been established, you should see the PROGRAM STATE LED flashing green. This indicates that the new program is running.

Programming Problem: PROGRAM STATE LED Red

If after programming and linking to an OI, the PROGRAM STATE LED is flashing red, there is a problem with the code that was downloaded. Possible causes include incorrect initialization of the microcontroller, the code loop taking too long to execute, or the code getting stuck in an infinite loop. Check for errors in the code. If any of these conditions occur, the Master processor will hold the entire Robot Controller in a reset state so that erratic operation does not occur.

If you are using the Dashboard Viewer software from Innovation First's web site, you can view the warning code which will tell you more details about the violation which caused the error.

Appendix A: Document Version History**Date Code Changes**

2005-01-13 Initial document release.

2005-01-18 Analog Input potentiometers allowable range, Section 9.