

Innovation First, Inc.

2004 Full-Size Control System Quick Start Guide

For the OI and Full-Size RC

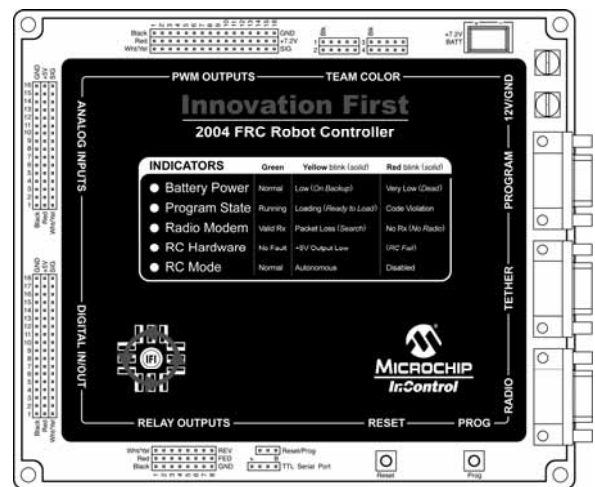
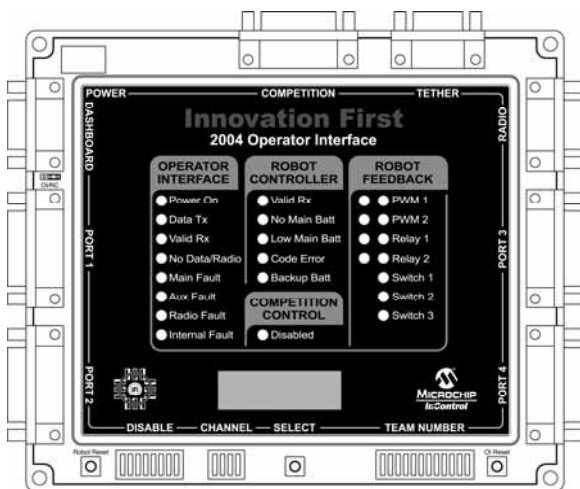

Table of Contents

1. System Overview	2
2. Tethered System Setup Guide.....	3
3. Wireless System Setup Guide.....	4
4. Setting Your Team Number.....	5
5. Testing the System.....	6

1. System Overview

The heart of the Innovation First Control System is an Operator Interface and a Full-Size Robot Controller. The Operator Interface takes inputs from the human operator(s) and passes it to the Robot Controller. The Robot Controller takes this information, gathers additional information from sensors on-board the robot, determines how the robot should function, and controls the robot to perform the functions. The Robot Controller also sends data back to the Operator Interface, giving the human operator(s) feedback of critical information.

The Innovation First control system uses a unique “Team Number” identification to ensure safe and reliable human to robot communication. Users enter their team number via dipswitches on the Operator Interface and then program this number into their Robot Controller one time by connecting the units via tether. Thereafter, both units will use this number as a unique identifier, ensuring that all communications received are actually theirs. Section 4 describes how to set the Team Number.

This document will show you how to connect the basic components of your system to verify proper operation. There is no need to program your Robot Controller, as it has been shipped with a default program already loaded. Before you start you will need to make sure that you have a fully charged 7.2V backup battery and a fully charged 12V main battery. For complete details on your Robot Controller and Operator Interface, refer to their respective reference guides.

2. Tethered System Setup Guide

This guide shows a diagram of the basic cabling required to begin using the control system in a tethered configuration. Also, this guide contains of a list of components required for the Quick Setup based on using the default program.

NOTE: The first time you try to use your RC and OI, you must connect them via tether (as shown here), before attempting to connect via radio (as shown on the next page). This is because the RC must obtain its team number from the OI by tether before it will be able to link wirelessly.

Robot Control System pieces:

- (1) Robot Controller
- (1) 12V Battery
- (1) 7.2V Backup Battery
- (1) RS 422 Radio (RC) Optional
- (1) DB9 M-F Cable (radio) Optional
- (1) Servo
- (1) DB9 F-F Cable (tether)

Operator Control System pieces:

- (1) Operator Interface
- (1) AC Adapter Optional
- (1) RS-422 Radio (OI) Optional
- (1) DB9 M-F Cable (radio) Optional
- (1) Joystick

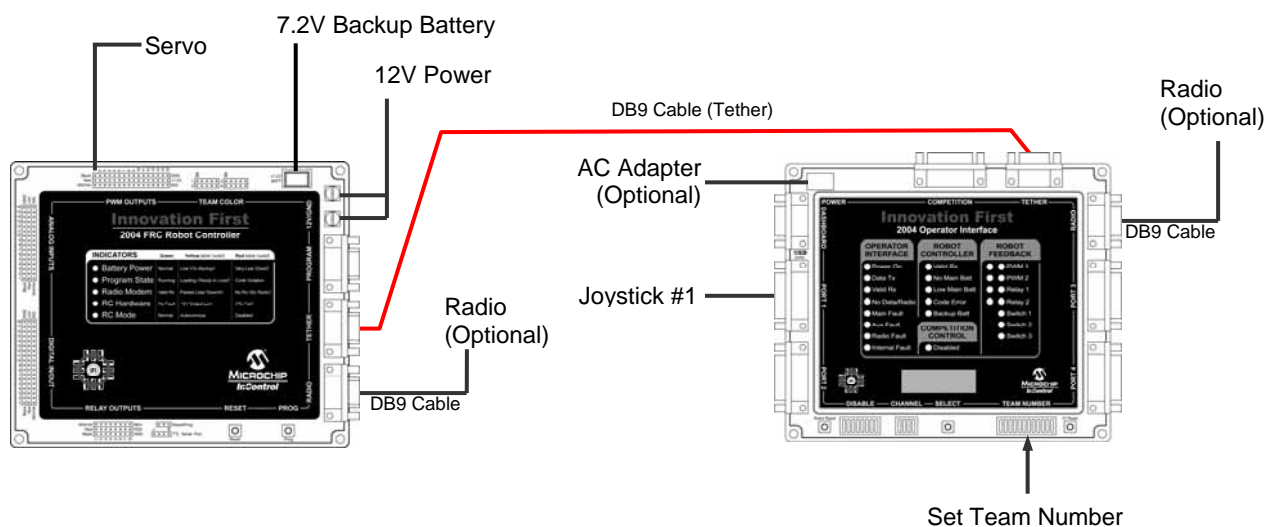

3. Wireless System Setup Guide

This guide shows a diagram of the basic cabling required to begin using the control system in a wireless configuration. Also, this guide contains of a list of components required for the Quick Setup based on using the default program.

NOTE: Before linking your RC and OI wirelessly, you must first link via tether once as shown on the previous page.

Robot Control System pieces:

- (1) Robot Controller
- (1) 12V Battery
- (1) 7.2V Backup Battery
- (1) RS 422 Radio (RC)
- (1) DB9 M-F Cable
- (1) Servo

Operator Control System pieces:

- (1) Operator Interface
- (1) AC Adapter
- (1) RS-422 Radio (OI)
- (1) DB9 M-F Cable
- (1) Joystick

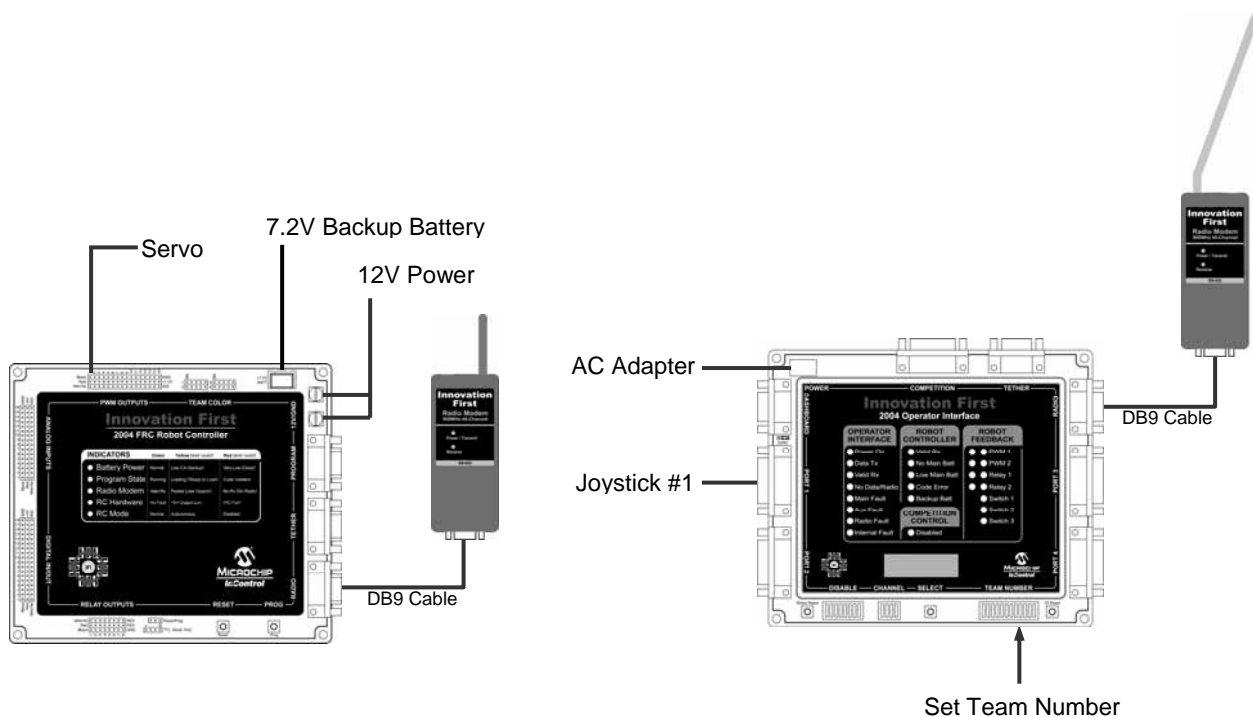

4. Setting Your Team Number

1. Power up the Operator Interface by connecting the AC Adaptor to 115V 60Hz power. Plug the AC Adaptor cable into the POWER connector on the Operator Interface (turning it ON).
2. Set Team Number:

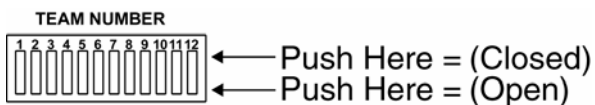

- a. Set each of the twelve TEAM NUMBER switches to the Switch Closed position. The Operator Interface display should show “0000” on the 4-digit display.

CAUTION: You cannot use a team number of zero. A team number of zero is reserved for Autonomous Mode. The Robot Controller set to a team number of zero will begin executing user code and could start moving if you have modified the default code.

- b. Set switch 1 Down and look at the display.

If the number displayed is greater than your team number, return the switch to Closed.

If the number displayed is less than your team number, leave the switch Open.

If the number displayed is your team number, go to step 4.

- c. Repeat step b. using the next switch (2, 3, 4 ...) until you achieve your team number.

3. Connect a battery to the Robot Controller to power-up the unit. The “Battery Power” light should now be flashing green.
4. Connect the “Tether” ports of the RC and OI with the red tether cable.
5. After a few seconds, the “Radio Modem”, “RC Mode”, and “Program State” lights should begin flashing green on your RC, and the two “Valid RX” lights should be flashing on your OI, indicating each is transmitting and receiving valid data with the correct team number.
6. The display on the Operator Interface will change to the channel number (c40).
7. You may now disconnect the tether cable and link up wirelessly. The RC will remember its team number even after power has been removed.

5. Testing the System

System Feature Overview

If you connect all of the components as shown and have properly set the team number, the system should be working correctly. Try the following to see how it works. Make sure you have a fully charged 7.2V backup battery and a fully charged 12V battery connected to your RC. Then connect a servo to PWM1.

1. You should center the Y axis on Port 1 using the trim tab on the Port 1 Joystick. With the joystick centered, move the trim tab until both “PWM1 Red” and “PWM1 Green” LEDs on the Operator interface are both ON. Both LEDs “ON” at once indicate that the joystick is centered.
2. Moving the PORT 1 joystick forward and back should move the servo connected to PWM1 output on the Robot Controller. If your servo doesn't move then your 7.2V backup battery may be dead.
3. When the PORT 1 “Y” axis joystick is all the way forward, the “PWM1 Green” LED on the Operator Interface should be ON, indicating full forward.
4. When the PORT 1 “Y” axis joystick is all the way back, the “PWM1 Red” LED on the Operator interface should be ON, indicating full reverse.
5. When pressing the trigger or thumb buttons on the Port 1 joystick, the RELAY 1 Green or Red LEDs on the Operator Interface will be ON, respectively.
6. Pressing the SELECT button on the Operator Interface will change the display between Robot Battery Voltage, User Mode, Team Number, and Channel Number. User mode is identified by a small “u” on the 4-digit Operator Interface display.

Note: All feedback LEDs on the Operator Interface are disabled while in User Mode.